



Motor Mounted Speed Control

1/8 HP, 90 VDC, 2.5 AMPS, FIELD INSTALLED

Designed to be easily field mounted on Bison PMDC motors, the speed control is mounted within an aluminum extrusion for superior heat dissipation. A simple knob provides a convenient on-off switch. Three adjustable potentiometers provide settings for minimum RPM, maximum RPM, and current limit. A pre-wired three foot long cord with plug is provided for use with 115V, 60 Hz.

- **Simple Mounting and Assembly.** Allows the drive to start working for you in the field as quickly as possible
- **Easy Operation.** Speed is controlled with a simple on/off potentiometer in conjunction with current limit, min. speed, and max. speed settings
- **All Metal Enclosure.** Durable aluminum housing with steel cover plates disperses heat more efficiently
- **Includes Power Cord with Plug.** Three foot power cord is included with a NEMA 5-15P plug for use with 115VAC 60Hz
- **More Consistent Speed Under All Loads.** SCR circuitry provides much more consistent speed throughout the motor's rated torque
- **Specifications.** Up to 2.5 AMPS (1/8 HP @ 90VDC)

TightDrive Motor Mounted Speed Control

Part Number	Input Voltage	Output Voltage	Max Current	Max Output Power	Enclosure Rating	Reversible?	Form Factor	UL / CUL	CE	ROHS
170-113-0003	115 Volt, Single Phase, 60 Hz	90 Volt, Direct Current	2.5 Amps	1/6 HP, 124 Watt	IP 30	Non-Reversible	1.37	Pending	Yes	Yes

Operational Specifications

Input Voltage @ 50/60 Hz	115 VAC
Maximum Output Voltage	90VDC
Maximum Continuous Duty HP	1/8

Feature Specifications

Speed Range	20:1
On/Off Switch	Yes

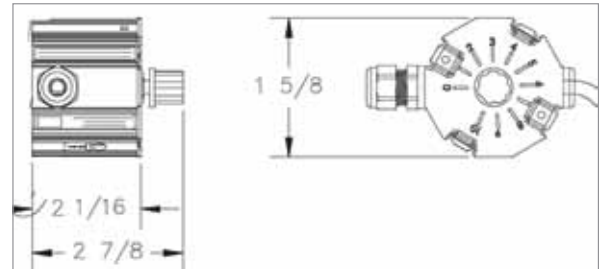

SCR Drives

SCR DC Chassis / NEMA 4X

Bison's SCR speed controls are dual voltage drives that can control speed or torque. When torque mode is selected, the functions of the speed and torque pots change. The external potentiometer sets the torque reference, the on-board torque pot sets maximum speed and the on-board Max Speed pot sets maximum torque.

- Accel / Decel Range 0.5 to 17 seconds
- User adjustable calibration pots: IR compensation, min speed, max speed, torque, acceleration and deceleration.
- Diagnostics: LEDs for power and current limit status
- Stopping Modes: coast to minimum speed or to stop with selectable N.O. or N.C. inhibit contacts. Decelerate to minimum speed via the pot circuit. Braking on enclosed reversing models.
- Spade and screw terminals: easy to use spade terminals on chassis; screw terminals on enclosed units.
- Flexible inhibit: Select with jumper pins the preferred inhibit functionality.



Dual Voltage SCR Speed Control

Part Number	HP Rating 230VAC	Output Amps (DC)	Configuration
170-103-0002	1/10-1/4	1.5	Chassis
170-103-0010	1/4-2	10.0*	Chassis
170-143-0002	1/10-1/4	1.5	NEMA 4X
170-143-0010	1/4-2	10.0*	NEMA 4X

*Heatsink #170-990-0100 required above 5 amp DC

Dual Voltage SCR Speed Controls

Input Voltage	115/230VAC +/- 10%, 60/50Hz, single phase
Output Voltage	0-90 or 0-180 VDC
Form Factor (AC amps/DC Amps)	1.37

Dual SCR Chassis

The Dual SCR drive provides the power of two drives in one! Now with one DC drive, you can control two different DC motors either independently or in a ratio mode. In independent mode, each side of the drive can be controlled differently with different trimmer pot settings and different speeds. In speed ratio mode, one speed potentiometer sets the main speed while the other one determines the ratio of the speeds between the motors. In this mode, the drive replaces two single drives and possibly a separate master/follower card resulting in extreme cost and panel space savings!

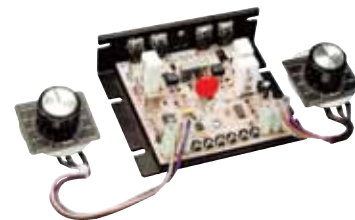

- Ability to control two different DC motors at once: Jumper selectable independent or speed ratio mode.
- Industry Standard footprint for chassis mount
- User adjustable calibration pots: Two each of minimum speed, maximum speed, IR compensation, current limit and acceleration / deceleration.
- Stopping Modes: Decelerate or coast (jumper selectable) using inhibit function (N.O.)
- Speed or Torque Mode: Jumper selectable. Speed mode regulates speed and limits current. Torque mode regulates current and limits speed.
- Microprocessor based: Can custom program the trimmer pot ranges and inhibit for OEM applications.
- Spade and screw terminals: easy to use spade terminals on chassis.
- Panel Space Saving: Replace two DC drives with one compact package.

Chassis SCR Speed Control for Two Motors

Part Number	HP Rating	Max Total HP	Output Amps (DC) each side	Max Total Amps of Both Sides	Configuration
170-101-0212	1/15-1/2 (per side)	5/8	10.0*	11.5*	Chassis

*Heatsink #170-990-0100 required whenever one side is more than 5 amps or the total of both sides is more than 6.5 amps

Chassis SCR Speed Control for Two Motors

Input Voltage	115VAC, 60Hz, single phase
Output Voltage	0-90 VDC
Form Factor (AC amps/DC Amps)	1.37

SCR NEMA 4X

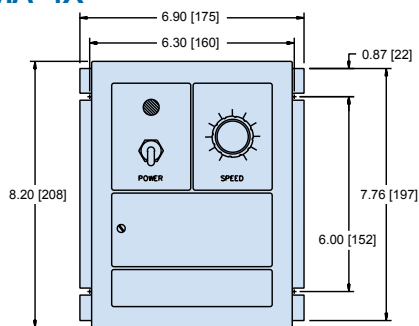

FOUR MOUNTING SLOTS 0.19 INCHES [5 MILLIMETERS] WIDE

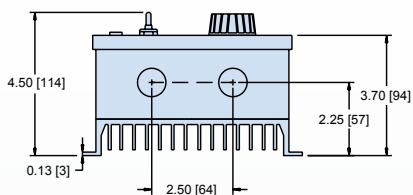

SCR DC Chassis

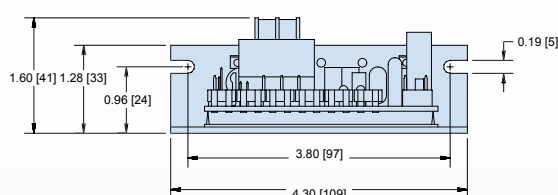
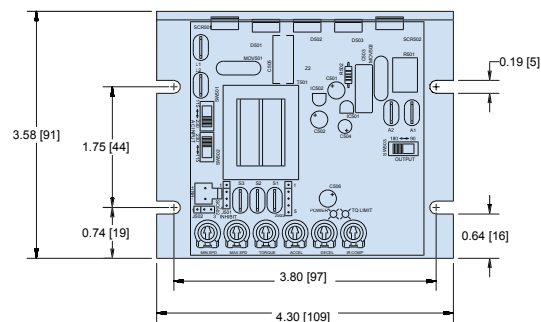

Dual SCR Chassis

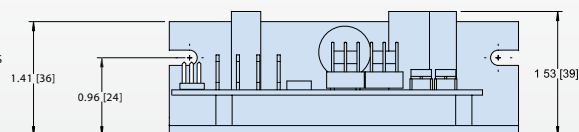
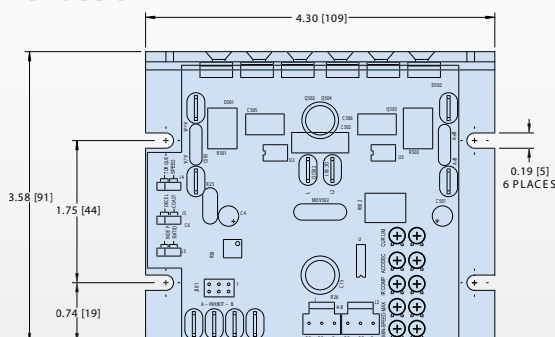

SERVOES & DRIVES

PWM Drives

PWM DC NEMA 4X

Bison's filtered pulse-width-modulated (PWM) variable speed DC drives provide exceptional performance. This series of drives, housed within a NEMA 4X enclosure, guarantees protection from washdown, corrosive material, windblown dust, incidental contact with enclosed equipment, or unwanted external solid objects.

- AC input power is dual voltage dual frequency 115/230VAC +/- 10%, 60/50Hz, single phase
- Output voltage is 0-130 or 0-240 VDC
- Form factor, (AC amps / DC Amps) at rated output power is 1.05
- NEMA 4X enclosure: Protects against external corrosive material and incidental contact.
- User adjustable calibration pots: IR compensation, min speed, max speed, current limit, acceleration and deceleration.
- Diagnostics: LED for power on front of enclosure
- Stopping modes: Coast to a stop with Power On/Off switch or via inhibit terminals (N.O.).
- Speed range and regulation: 1% regulation over 100:1 speed range.



Dual Voltage PWM Speed Controls NEMA 4X

Part Number	HP Rating 120 VAC	HP Rating 240 VAC	Field Supply (VDC)	Output Amps (DC)	Configuration
170-243-0003	1/20-1/3	1/8-1/2	50/100/200 (1 Amp)	3.0	NEMA 4X

Dual Voltage SCR Speed Controls NEMA 4X

Input Voltage	115/230VAC +/- 10%, 60/50Hz, single phase
Output Voltage	0-130 or 0-240 VDC
Form Factor (AC amps / DC amps)	1.05

PWM DC CHASSIS

Bison's filtered pulse-width-modulated (PWM) variable speed DC drives output nearly pure DC power to brush type motors and feature the same footmount as the SCR controls.

- User adjustable calibration pots: IR compensation, min speed, max speed, current limit, acceleration and deceleration.
- Diagnostics: LEDs for power and current limit status
- Cage Clamp Terminal Block: Quick and easy wire terminations reduce installation time!
- Spade and screw terminals: easy to use spade terminals on chassis
- 16.5 kHz switching frequency: A high switching frequency means a quiet motor.
- Speed range and regulation: 1% regulation over 100:1 speed range.



Dual Voltage PWM Speed Control Chassis Style

Part Number	HP Rating 120 VAC	HP Rating 240 VAC	Output Amps (DC)	Configuration
170-203-0002	1/20 to 1/4	1/10 to 1/2	2.0	Chassis
170-203-0005	1/4 to 1/2	1/2 to 1	5.0	Chassis

Dual Voltage SCR Speed Controls Chassis Style

Input Voltage	120/240VAC +/- 10%, 60/50Hz, single phase
Output Voltage	0-130 or 0-240 VDC
Form Factor (AC amps / DC amps)	1.05

Low Voltage PWM DC

Bison's DC in/DC out PWM chassis drives include inhibit for remote starting and stopping, a power LED, and trimmer pot adjustments for minimum speed, maximum speed, acceleration, IR comp, and current limit. All trimmer pots are non-interactive making calibration quick and easy.

- Speed range and regulation: 1% regulation over 80:1 speed range
- User adjustable calibration pots: IR compensation, min speed, max speed, current limit and acceleration.
- Diagnostics: LED for power
- Stopping Modes: The user can coast the motor to a stop (N.O.) using inhibit circuitry.
- Spade and screw terminal block: easy to use
- DC Input Voltage Range: Accepts DC inputs and outputs DC voltage up to 95% of the input with near perfect form factor.
- One Drive for two motor voltages: On board jumper to select 12 or 24V motor.
- Ideal for battery powered equipment: Maintains variable speed control even as battery voltage declines. Extends total running time of equipment.
- Additional features include extruded chassis and non-interactive trimmer pots.



DC to DC PMW Controller for 12V & 24V Motor

Part Number	HP Rating	Output Amps (DC)	Configuration
170-205-0016	1/4 to 1/2	16.0	Chassis

DC to DC PWM Controller for 12 & 24V Motor

Input Voltage	10 to 32 VDC
Output Voltage	Up to 95% of input voltage
Form Factor (AC amps / DC amps)	1.01

PWM DC NEMA 4X

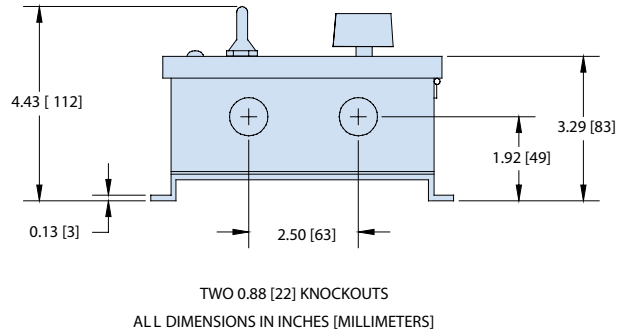
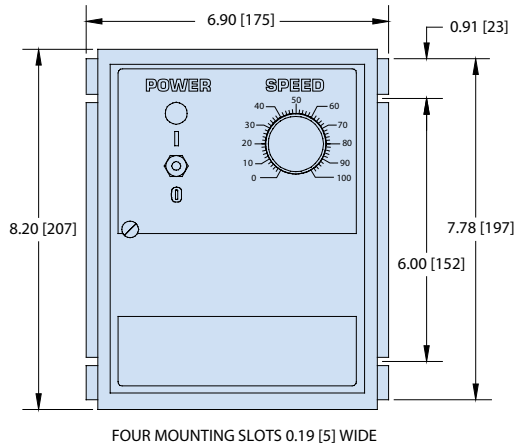

PWM DC Chassis

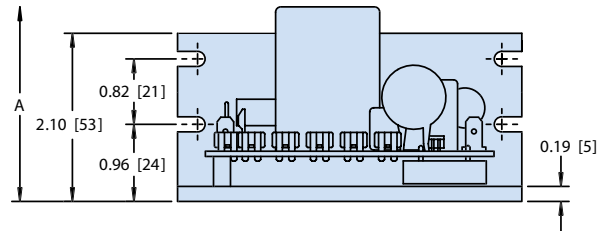
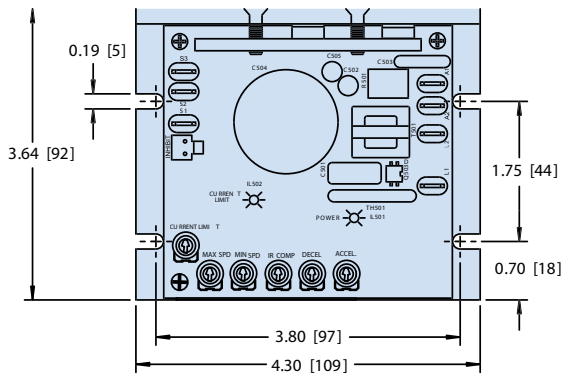

Low Voltage PWM DC

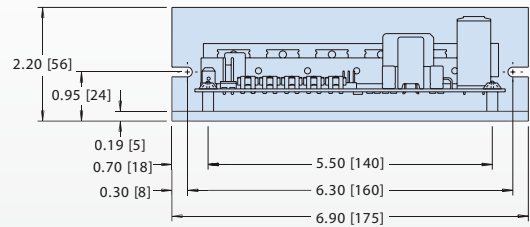
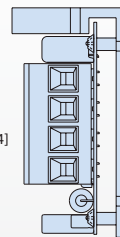
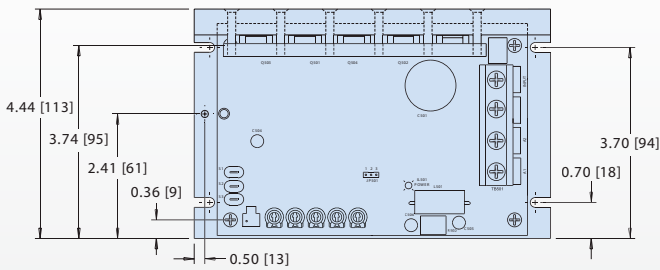

Regenerative Drives

SCR DC Regen CHASSIS / NEMA 4X

Bison's Regen Drives consist of full-wave, four-quadrant regenerative SCR controls to provide smooth motoring and braking torque for brush-type DC motors. Control motors from 1/20 through 1 HP for single or bi-directional variable speed, without using mechanical contactors.

- Speed Range and Regulation: 1% regulation over 50:1 speed range.
1% regulation over 60:1 speed range with the addition of a tachometer for feedback.
- 4 Quadrant Reversing: Regenerative / 4 quadrant drives have the ability to perform quick, contactorless, reversing on-the-fly.
- Stopping Modes: User can decelerate (N.O.), regeneratively brake (N.O.) or coast the motor to a stop (N.O.). User can also decelerate to minimum speed (N.O.).
- Cage Clamp terminal block: Quick and easy wire terminations.
- User adjustable calibration pots: IR compensation, forward torque, reverse torque, tachometer, min speed, max speed, forward acceleration, reverse acceleration and deadband.
- Additional Features: Dual voltage AC input, switch selectable armature or tachometer feedback mode and field supply for shunt wound motors.
- On board fusing: No need to add external fusing for protection of your motor or drive.



SCR Four Quadrant Regenerative Drives

Part Number	Horsepower	Output	Configuration
170-303-0003	1/20-1/8	3.0	Chassis
170-303-0010	1/8-1	10.0*	Chassis
170-343-0003	1/20-1/8	3.0	NEMA 4X
170-343-0010	1/8-1	10.0	NEMA 4X

* Heatsink #170-990-0300 required above 7Amps DC.

SCR Four Quadrant Regenerative Drives

Input Voltage	115/230VAC +/- 10%, 60/50Hz, single phase
Output Voltage	0-90 or 0-180 VDC
Form Factor (AC amps / DC amps)	1.37
Field Supply Voltage	50/100/200

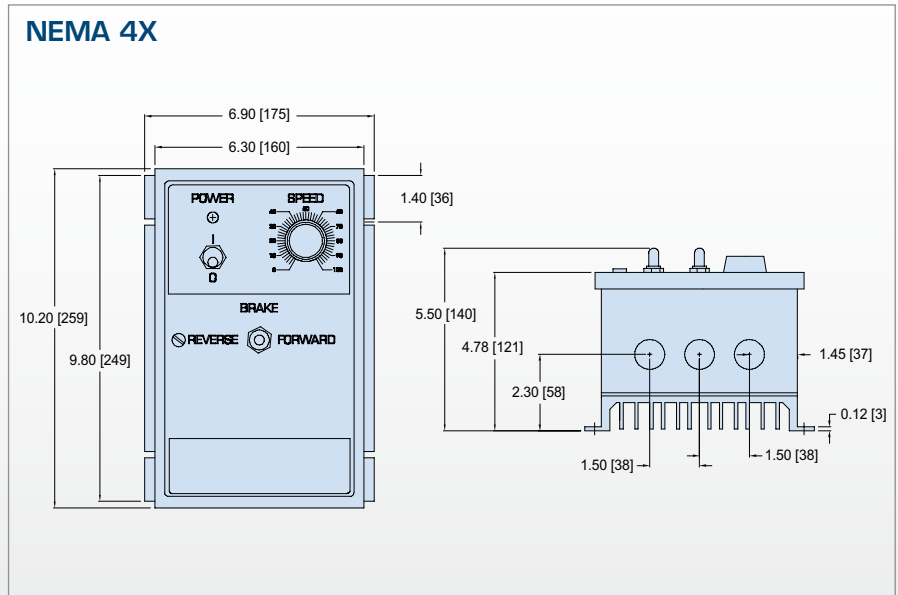
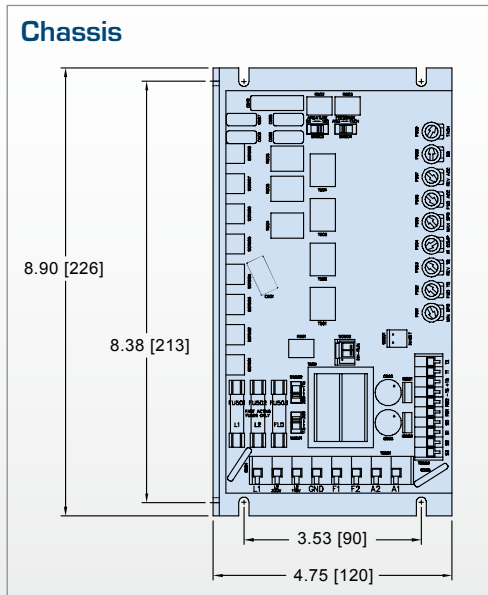

Variable Frequency Drives



Isolated PWM AC NEMA 4X

Bison's variable frequency Drives feature a lightweight, plastic NEMA 4X enclosure, an isolated front end, minimum speed adjustment potentiometer (pot), output voltage doubling, DC injection braking, and automatic or manual restart when power is restored.

- NEMA 4x enclosure: Compact, easy to mount, black plastic enclosure.
- Isolated inputs: Accepts floating or grounded signals 0-10VDC, 0-5VDC or 4-20 mA
- User adjustable calibration pots: Minimum speed, maximum speed, current limit, acceleration, deceleration, slip compensation, boost, zero set, brake current, and brake time.
- Diagnostic LED's: Power, fault, and torque limit
- Stopping modes: DC injection braking or coast (jumper schedule)
- Adjustable 4 to 16 kHz switching frequency; Quiet motor operation or reduced electrical noise.
- Quick Disconnect terminal block: Allows up to 200% torque to overcome intermittent peak loads.
- Additional features: Auto or manual restart after low input voltage fault (jumper selectable), line fusing, enable and direction inputs.

Variable Frequency AC Chassis Drive

Part Number	Input Voltage	HP Rating	Output Current	Output Frequency	Configuration
170-503-0002	115 or 230V Single Phase	1/6 to 1/2	2.4A	0-120 Hz	Chassis

PWM NEMA 4X

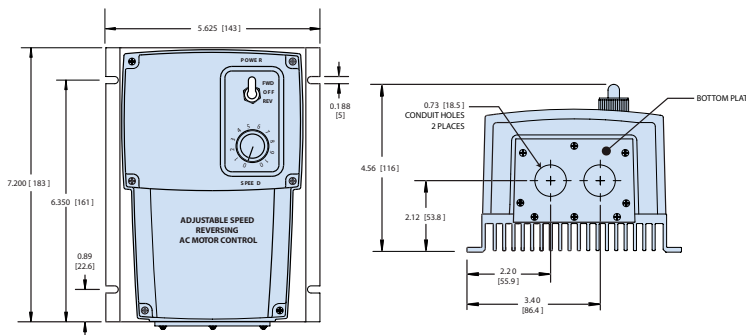

PWM AC Chassis

The cost-conscious and compact chassis design of Bison VFD Chassis Drives maintain the industry standard for mounting hole location and the coded LEDs make it easy to visually determine the drive status. With it's compact design and application flexibility, this is an excellent choice for most AC applications.

- Compact Size: 4.3" x 3.7" Easy to mount in small spaces with industry standard mounting hole pattern.
- Easy to Calibrate & set up: On board trimmer pot adjustments for boost, maximum speed, acceleration, deceleration.
- Torque "foldback" feature: Allows up to 200% torque for short periods to overcome intermittent peak loads, then reduces the torque to a preset safe level.
- 16kHz switching frequency, with option to change between 4 and 16 kHz in the field: A high switching frequency results in quiet motor operation. Adjustments to a lower frequency if desired can be done in the field.

Variable Frequency AC Chassis Drive

Part Number	Input Voltage	HP Rating	Output Current	Output Frequency	Configuration
170-503-0002	115 or 230V Single Phase	1/6 to 1/2	2.4A	0-120 Hz	Chassis

PWM Chassis

